

The logo for LAPWOOD GmbH is centered in the image. It features a stylized diamond shape composed of five parallel, slightly curved lines that create a sense of depth and movement. Below this graphic, the text "LAPWOOD" is written in a bold, black, sans-serif font, with "LAP" on the left and "WOOD" on the right. Underneath "LAPWOOD", the text "GmbH" is written in a smaller, black, sans-serif font. The entire logo is overlaid on a background of a wooden yard with stacks of logs and planks.

LAPWOOD
GmbH



...Dein Hersteller von Holzverpackungen!

Wer wir sind?

Wir sind der zertifizierte Hersteller von Holzverpackungen. Kerngeschäft unseres Unternehmens ist die Herstellung von Holzpaletten und Kisten.



Sitz

In unseren Standorten haben wir eigene Sägewerk, Produktion und Fertigung. Im Büro haben wir Verkaufabteilung, Buchhaltung und Logistikabteilung.



Produktion

Der automatisierte Prozess setzt sich aus Maschinen und Robotern zusammen. So werden unsere Paletten qualitativ hochwertig hergestellt.

Die Produktion wird mit Hilfe von Computersystemen und Sensoren unterstützt.



Maschinenpark

In der Holzwerkstatt wird ein professioneller, moderner Maschinenpark eingesetzt.

Dies ermöglicht uns die Durchführung fortschrittlicher Projekte.



Wir trocknen unsere Produkte unter besonderen Bedingungen.



**ŁUKASIEWICZ RESEARCH NETWORK –
WOOD TECHNOLOGY INSTITUTE**
Winiarska 1, 60-654 Poznań, Poland
Phone: +48 61 849 24 00, E-mail: office@itd.poznan.pl
www.itd.poznan.pl

CERTIFICATE

No 323-ZFT – 746/2021

Examination Objective:
Technical and organizational conditions for the production of wood packing material in the company:
„LAPWOOD”
Production Plant: PL 62-560 Skulsk, ul. Targowa 2 A

Customer: „LAPWOOD” S.C. M. Łukaszewski, B. Jędrzejczak
PL 62-500 Konin, ul. 3 Maja 70/8

Scope of examination:

- checking of the type and technical condition of drying-kiln,
- checking of applied heat treatment schedules and methods of recording of heat treatment process,
- random inspection of the quality and moisture content of wood before treatment,
- random inspection of the quality and moisture content of wood after treatment,
- checking of supervising method of the production process,
- checking of handling methods with wastes, defective raw materials and products.

Method of examination: The method developed in Wood Technology Institute

References:

- International Standards for Phytosanitary Measures No. 15 (ISPM 15),
- Regulation (EU) 2016/2031 of the European Parliament and of the Council of October 26, 2016 on protective measures against pests of plants,
- The Act of February 13, 2020 on the protection of plants against pests.

Decision:
Technical and organizational conditions of wood heat treatment in the company „LAPWOOD” assure that the production of wood products complies with the phytosanitary requirements as specified in the reference documents. Equipment and processes guarantee the heat treatment with a minimum temperature of 56°C for a minimum duration of 30 continuous minutes throughout the entire profile of the wood, including its core (HT marking of the products is authorised).

Number in: NATIONAL LIST OF CODES OF THE MANUFACTURERS OF WOOD PACKAGING MATERIAL ACCORDING TO THE STANDARD FAO/IPP/ISPM 15: PL - 30 716

Certificate's Validity Period: until 09.12.2023

Annex: Examination Report No. U – 746/ ZFT/2021

mgr inż. Dominik Starzonek



dr hab. inż. Marek Władysław Przybylak

Poznań 10.12.2021

Branche, in denen unsere Produkte verwendet werden

- ✓ Automotive
- ✓ Kartonagen
- ✓ Papier
- ✓ Lebensmittel
- ✓ Möbel
- ✓ Online-Shop
- ✓ Transport
- ✓ Druckerei
- ✓ Elektronikindustrie
- ✓ Verpackungen
- ✓ Kunststoffindustrie
- ✓ Armaturen
- ✓ Fahrradbranche
- ✓ Fahrzeugteile
- ✓ Pharmaindustrie
- ✓ Solartracker
- ✓ Türenindustrie
- ✓ Baumaschinen
- ✓ Betonindustrie
- ✓ Ablufttechnik
- ✓ Metallindustrie
- ✓ Stahlindustrie



A blurred satellite map of Europe is shown in the background. The text "Wir liefern an jeden Ort." is centered over the map in a bold, black, sans-serif font. The map shows the continent of Europe with various shades of green and brown, indicating different terrain types, and the surrounding blue oceans.

Wir liefern an jeden Ort.

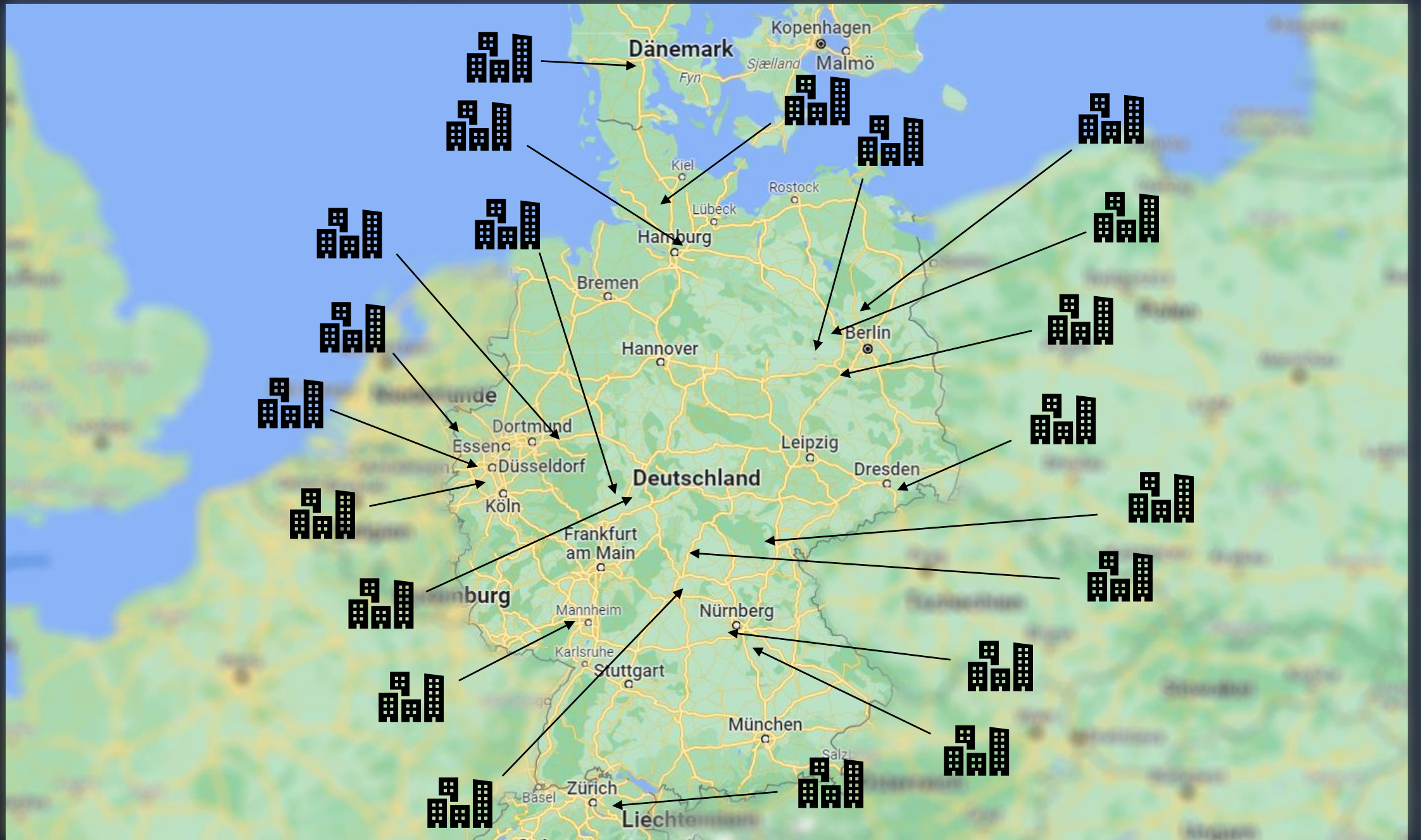



Produkte

Palettenböden

Paletten

Kisten



Palettenböden

3090x1600 (mm)

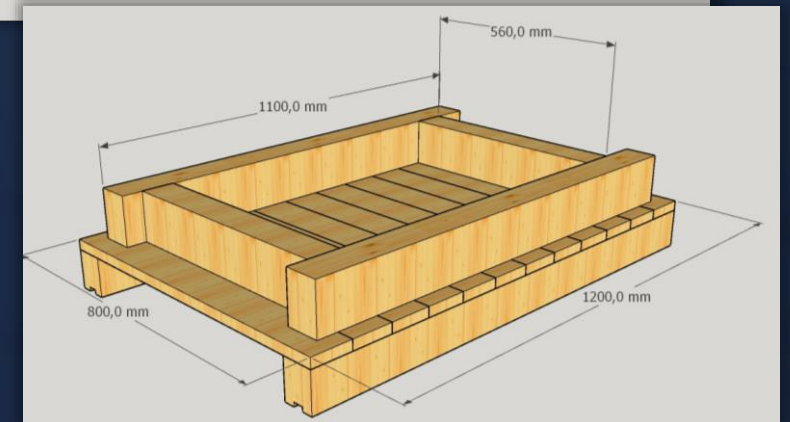
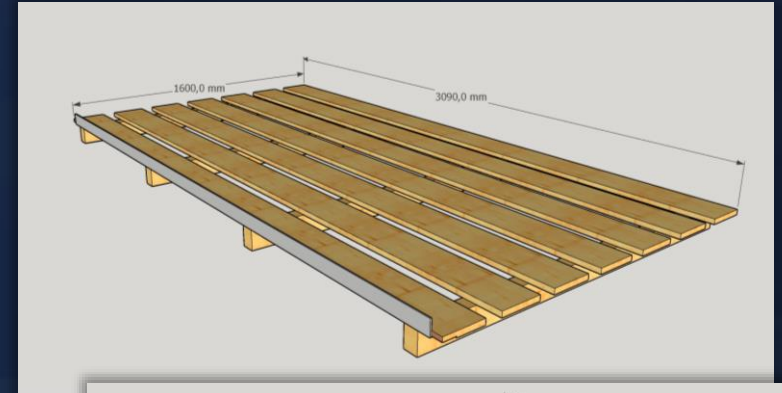

1200x800 (mm)

Palettenböden





Paletten

1200x1000 (mm)

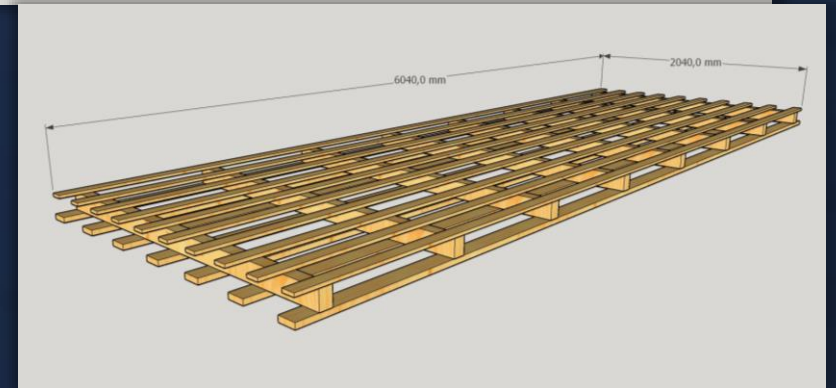
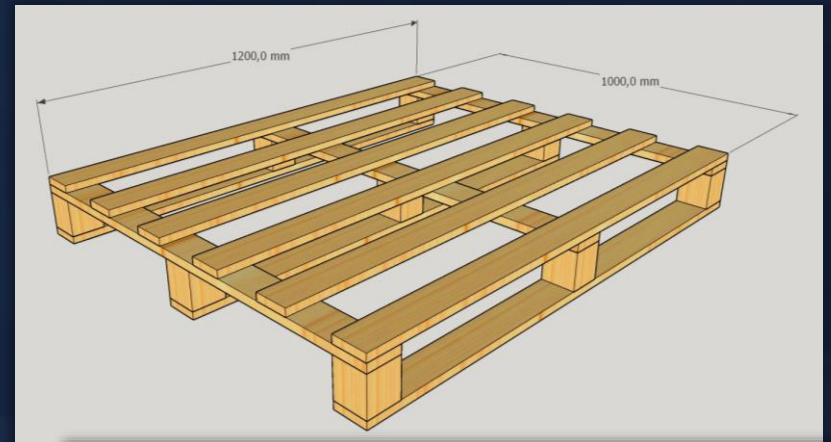

6040x2040 (mm)

Paletten



6000x2000 (mm)



2750x2340 (mm)



1600x800 (mm)



Kisten



730x474 (mm)

3300x1200 (mm)

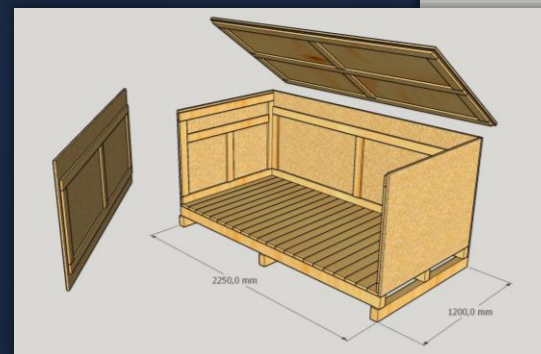

2250x1200 (mm)

Kisten



3200x1150x800
(mm)



3500x200x200
(mm)



5000x160x200
(mm)



Aufsatzrahmen

Kanthölzer

Holzgestelle

Verpackungsbretter

Deckel



Aufsatzrahmen



1200x800x200
(mm)



Kanthölzer

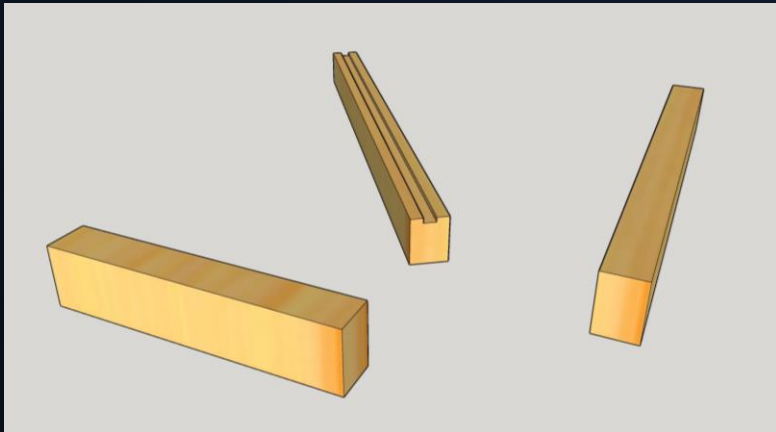

Holzgestelle

2141x1242x842
(mm)



1242x1191x1198
(mm)

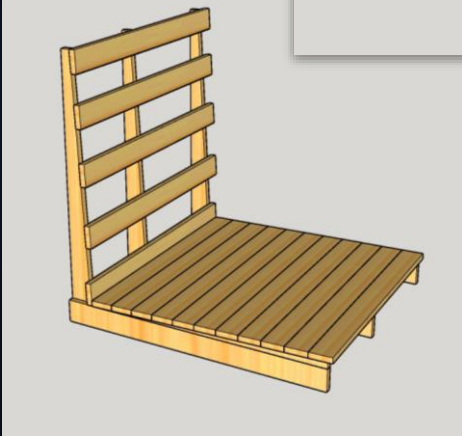
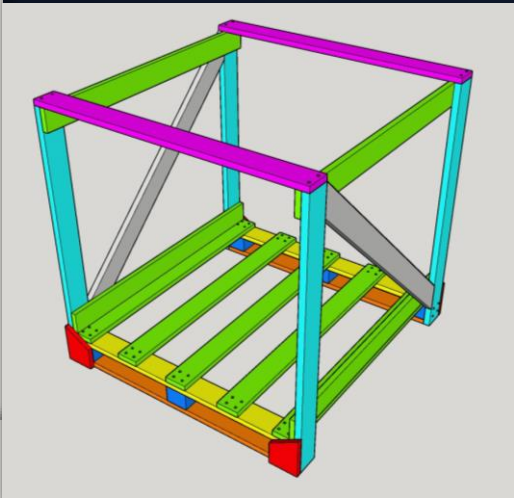

1000x1000x1000
(mm)



Verpackungsbretter

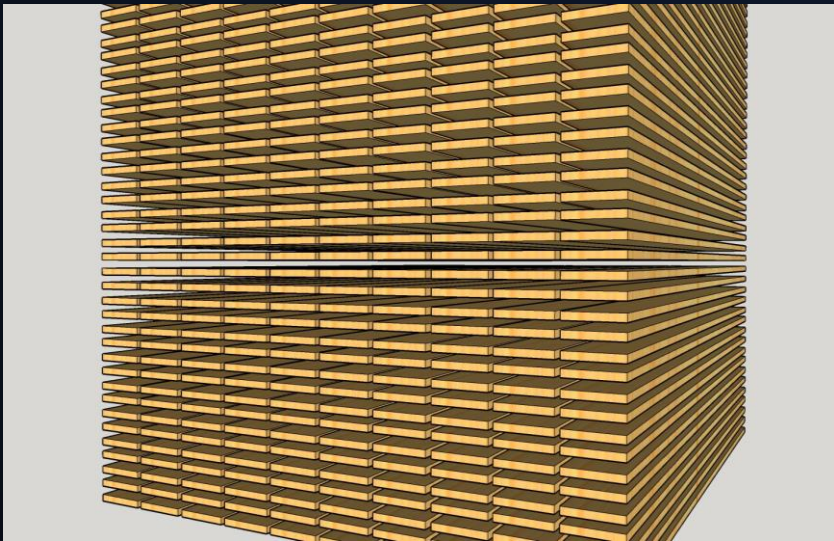

Deckel

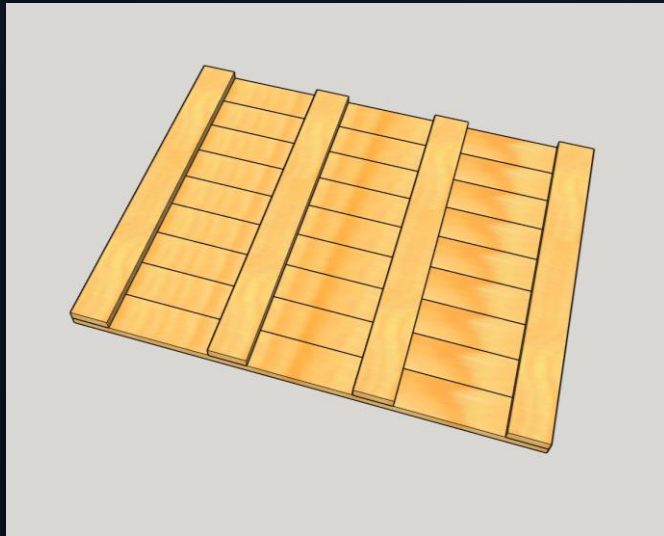

Ungewöhnliche Projekte



Unser fortschrittlichstes Design.

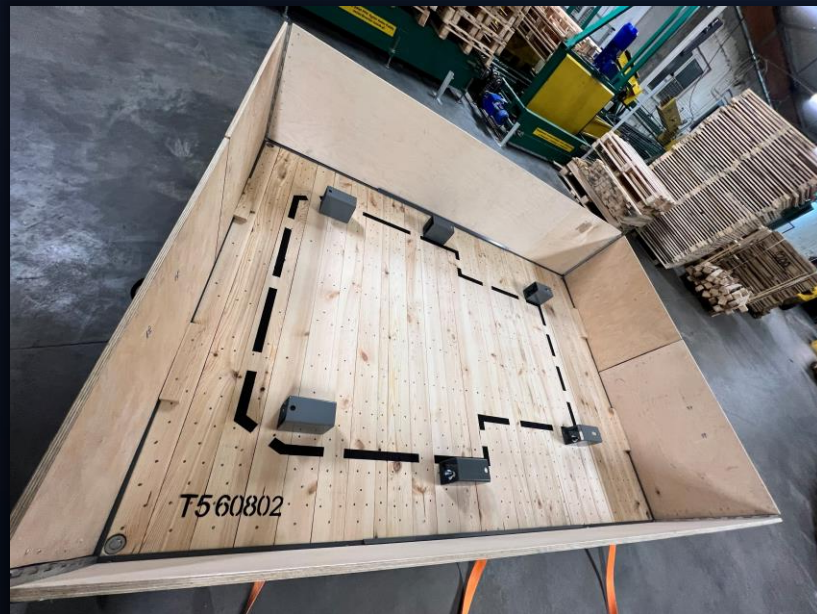

Li-Ionen-Batteriekasten für die Automobilindustrie.



2400x1800 (mm)

Ungewöhnliche Projekte

Wir fertigen sie für individuelle
Kundenbestellungen. Wir kombinieren
Elemente nicht nur aus Holz.

Welches Angebot können wir für Sie vorbereiten?





Marco Castiglione

Key Account Manager

+49 171 311 8231

marco.castiglione@lapwood-gmbh.de

LAPWOOD GmbH

Kleine Friedensstraße 24

15328 Küstriner Vorland

Ot Küstrin- Kietz DE

Ust. ID-Nummer: DE358038147

The logo for LAPWOOD GmbH is centered in the image. It features a stylized diamond shape composed of five parallel, slanted black bars. Below this graphic, the text "LAPWOOD" is written in a bold, black, sans-serif font, with "LAP" on the left and "WOOD" on the right. Underneath "LAPWOOD", the text "GmbH" is written in a smaller, black, sans-serif font. The entire logo is overlaid on a background of stacked lumber. In the foreground, several light-colored wooden planks are visible, while in the background, there are large stacks of dark-colored logs and a blurred building with a grid-like facade.

LAPWOOD
GmbH